

FLAMEC®

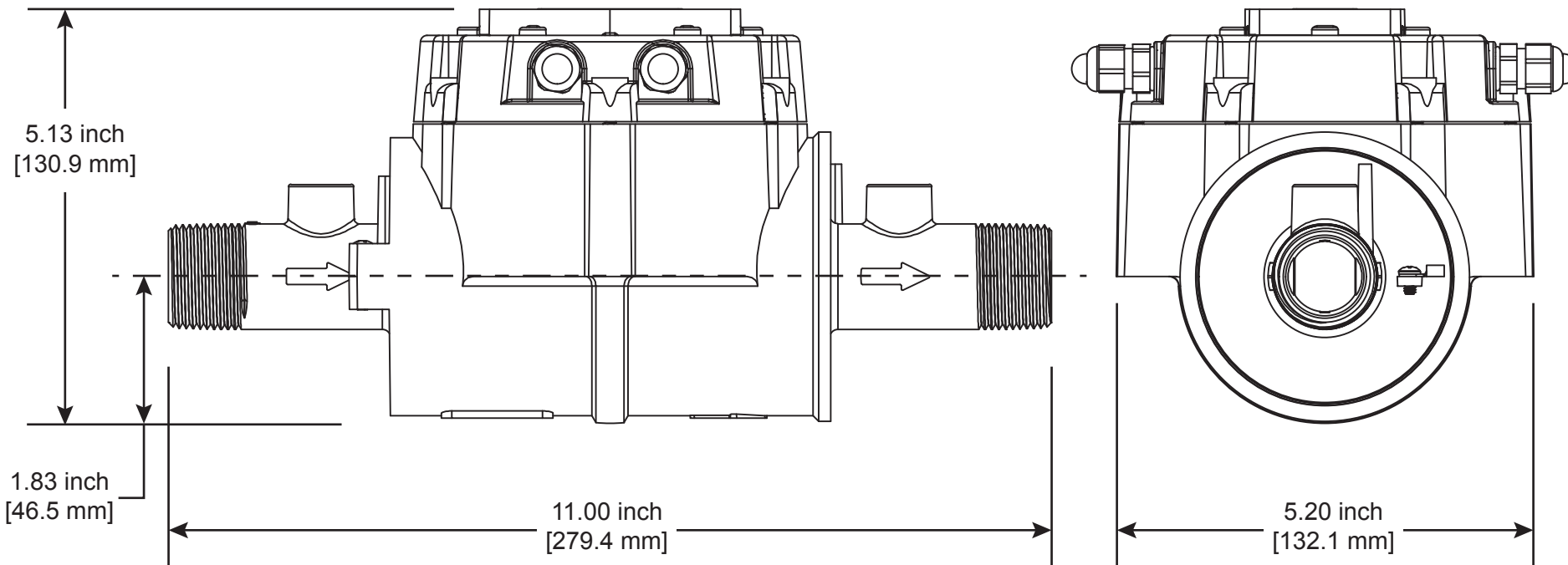
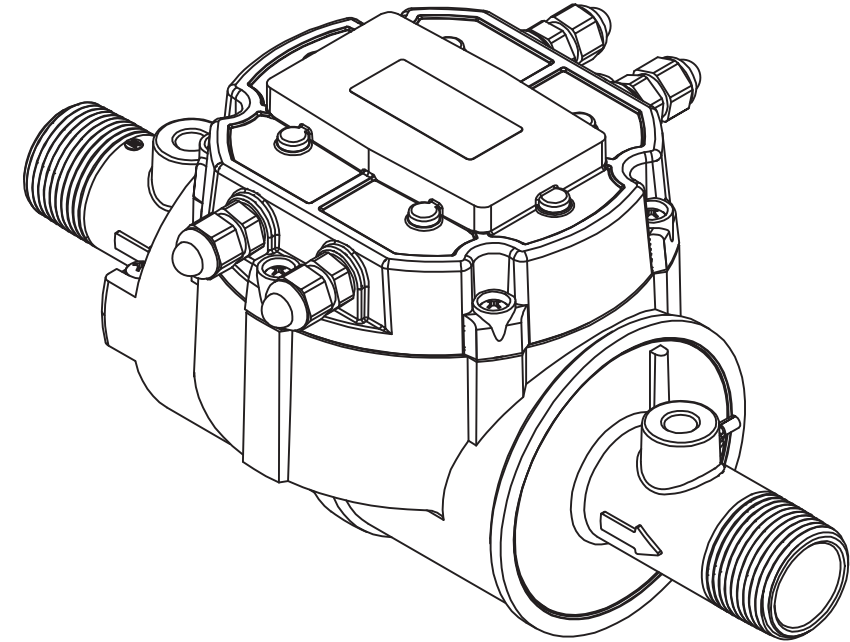
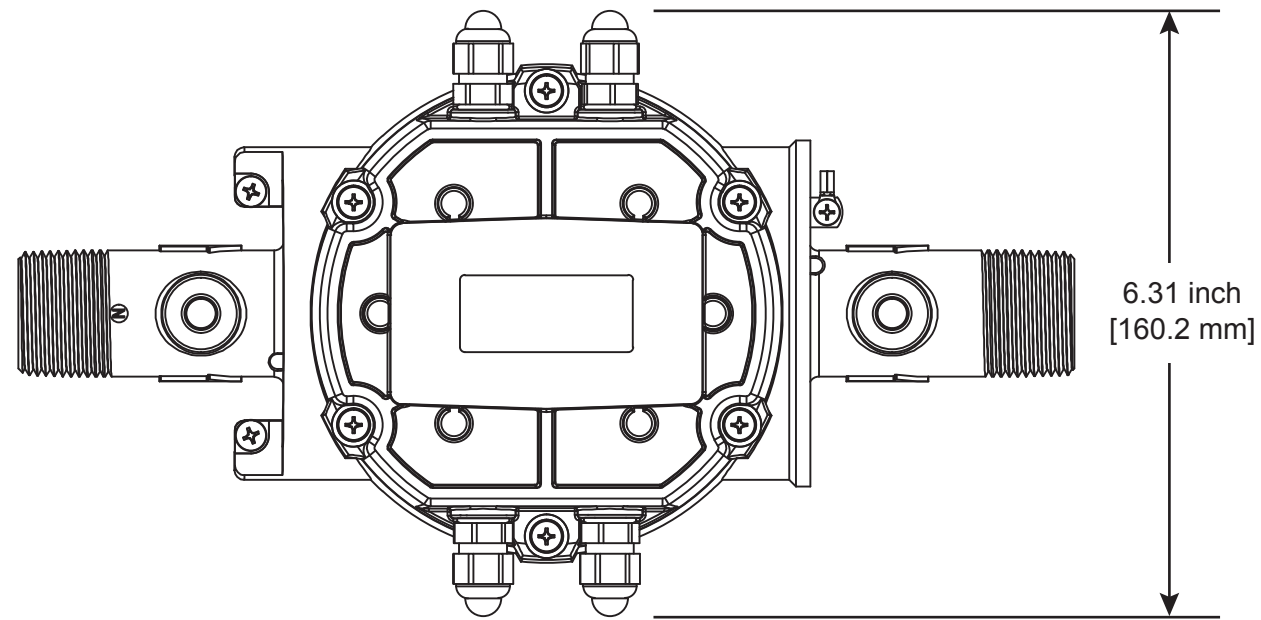

SPECIFICATIONS

Display:	Blind	
Fitting Size:	1 inch	
Fitting Type:	NPT Male	
Flow Range:		
Velocity - 0.25 to 15 FPS	0.6 - 40 GPM	2.27 - 151 L/m
Accuracy (% of Reading):		
± 2.0%	0.6 - 2.4 GPM	2.27 - 9.08 L/m
± 0.5%	2.41 - 40 GPM	9.09 - 151 L/m
Typical K-Factor	1,089 PPG	287.7 PPL

QSE MAG METER - QSE10NPTQB

Wichita · Sydney · Mexico City

GREAT PLAINS INDUSTRIES 

Great Plains Industries, Inc. / 888-996-3837 / flomec.net
Great Plains Industries, Inc. Australia / +61 2 9540 4433 / flomec.net